

## A Highly Dense, 64-Multichannel Acquisition System with Unique Synchronous and Phase Coherent Signal Processing Capabilities

by [Etienne Bequin](#), [Keysight Technologies](#)

By providing innovative solutions that realize multichannel synchronization, high-speed ADC technology aims to simplify data acquisition systems and push the limits of processing speed. Keysight Technologies recently introduced a 64 synchronous, multichannel data acquisition system composed of eight M9703A AXIe 12-bit high-speed digitizers/wideband digital receivers in a 14-slot chassis (Figure 1). The system was developed by Keysight in partnership with Scientific Equipment company who involved IPrium to build a complete solution for an enterprise leader in satellite telecommunication systems, whose main requirements were for multichannel synchronization and a FPGA programming capability.

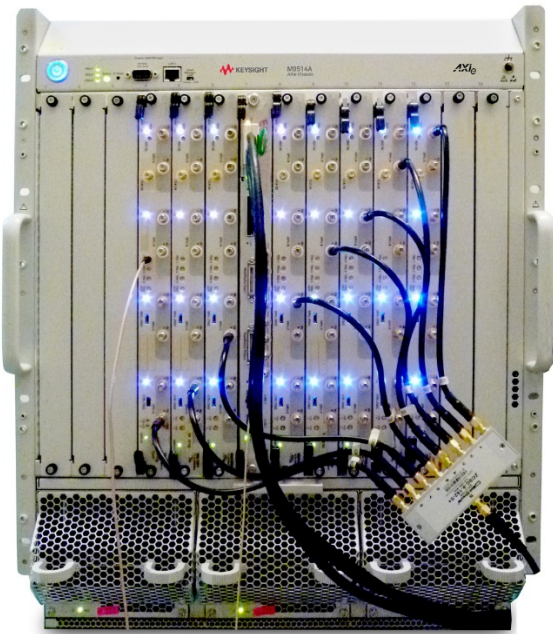

Figure 1. Shown here is a highly dense, 64 synchronous multi-channel data acquisition system with unique phase coherency. It's composed of eight M9703A 12-bit AXIe high-speed digitizers in a M9514A 14-slot AXIe chassis.

The multichannel multi-board synchronization for this application was enabled by two key factors: a common clock reference distributed to each module that ensured synchronous clocking of each ADC channel, and a dedicated multi-board synchronization infrastructure that allowed for phase coherency of each Digital Down Conversion (DDC) Local Oscillator (LO).

The synchronous clocking capability stemmed from the use of a dedicated time-base design that uses a unique Keysight IC distribution clock to deliver an ADC sample clock de-skewing capability with only 25 fs of added jitter. Phase coherency of the DDC LO was managed via a dedicated control FPGA. It allows for system synchronization of all DPU FPGA located on a single module, and with the control FPGAs of all adjacent modules.

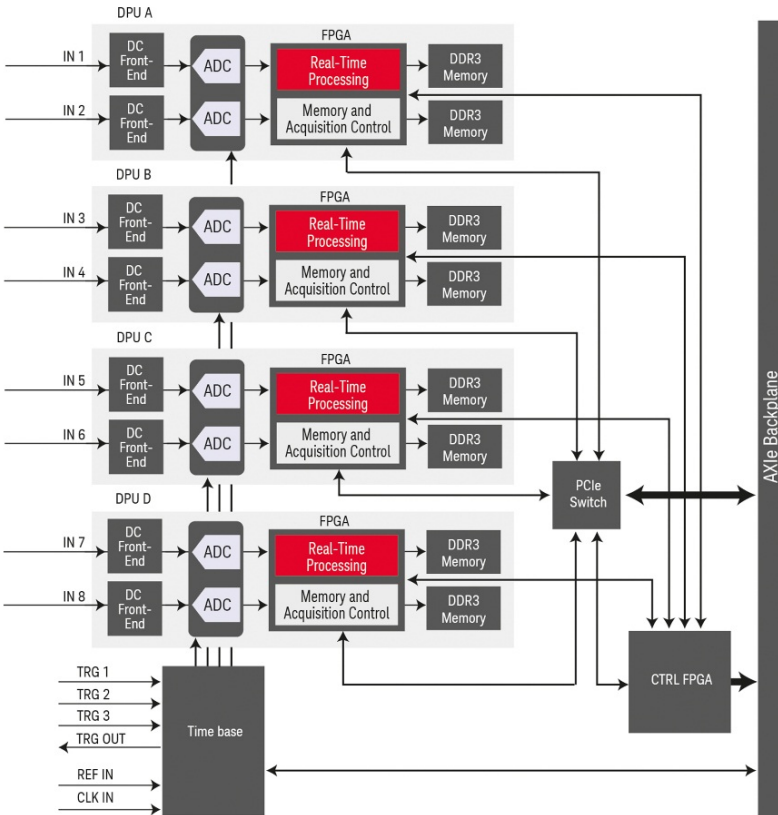

Figure 2. Simplified block diagram of M9703A AXIe Digitizer.

With an on-board FPGA, it is possible to implement dedicated real-time data processing that minimizes data transfer volumes and speeds analysis time. To respond to the customer’s need for dedicated processing, including both DDC and beamforming capabilities, dedicated FPGA firmware was developed using the Keysight U5340A FPGA Development Kit (FDK). The system functionality relies both on the real-time signal processing capability of the on-board FPGA and on the multi-board scalability of the point-to-point inter-FPGA data link infrastructure provided by the M9703A. With this scalability, the 64-channel configuration could potentially be extended up to 104 channels by simply increasing the number of M9703A modules within the AXIe chassis.

### An AXIe-Enabled Solution

The Keysight 64-multichannel data acquisition system was in many ways enabled by AXIe. AXIe products and, in particular the M9703A, provide the ideal infrastructure to implement a beamforming application across multiple AXIe modules. This is accomplished by leveraging the AXIe local bus point-to-point data transfer capability. The AXIe Timing Interface and AXIe Trigger bus provide the channel synchronization infrastructure, sharing the AXIe CLK100 reference clock to each M9703A and the AXIe SYNC synchronization signal. And, thanks to the multiple AXIe chassis available, a large degree of system scalability, ranging from 16 channels up to 104 can theoretically be provided.

In addition to these benefits, modular solutions based on AXIe products are extremely compact, which means that the size of the overall solution can be reduced, while allowing for more acquisition channels. With its innovative design, the Keysight 64- multichannel data acquisition system features eight digitizers within one chassis (Figure 3).

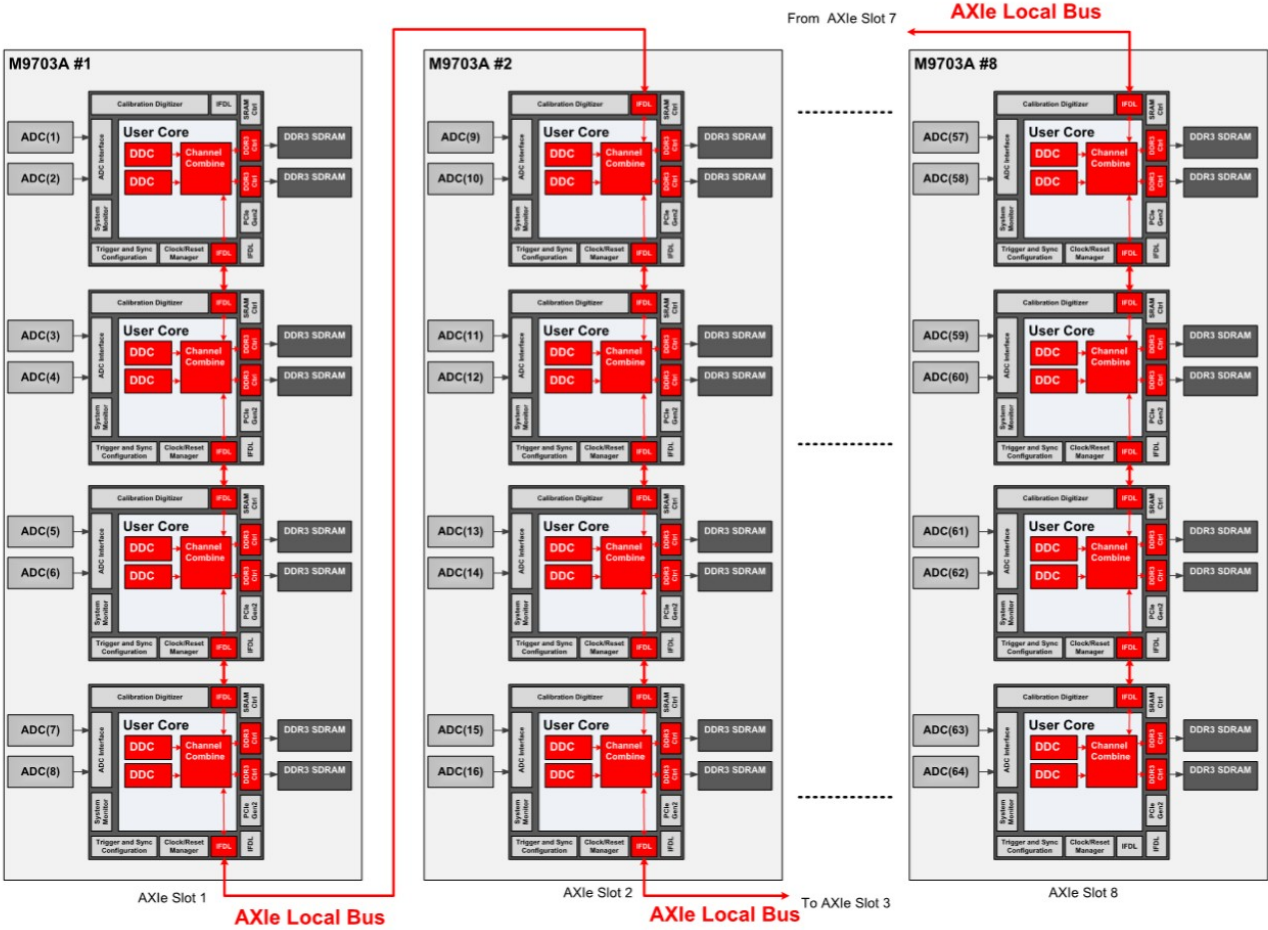

Figure 3. This system block diagram emphasizes the added value of the AXIe local bus, which synchronizes the eight M9703A AXIe digitizers and enables inter FPGA communication for beamforming.

"The key element of this system is the AXIe multi-channel, multi-board synchronization capability, which makes a high-speed, multi-channel data acquisition with customized, real-time signal processing and unique phase coherency possible," said Pierre-François Maistre, R&D project manager at Keysight Technologies. "We have already validated this 64-channel data acquisition system according to our customer's requirements and are now looking at increasing it to 104 channels."

The 64-channel modular system is composed of:

- Eight M9703A AXIe 8-channel, 12-bit high-speed digitizers/wideband digital receivers able to capture signals from DC up to 2 GHz at 1.6 GS/s.
- One U5340A FPGA development kit that provides a complete environment for the deployment of real-time, user defined signal processing algorithms on high-speed digitizers.
- One M9514A AXIe 14-Slot chassis that provides 13 instrument modules slots plus an AXIe system slot.
- One M9521A AXIe system module that provides the required system communication and synchronization functions.

### Creating a Complex FPGA Custom Design

Keysight's 64-channel modular system represents an important achievement in the design of customized applications with AXIe products. As Danil Shendrik, member of the IPrium design team that customized the application for the final client, explains, "Our task was to implement a 64-channel receiver with the ability to select the band-of-interest from DC to 400 MHz and bandwidth from 50 kHz to 50 MHz. The specific challenge of this project was to combine the data of all 64 channels with precise amplitude and phase control. The M9703A wideband digitizer is a powerful solution for multi-channel digital signal processing and, equipped with the U5340A FPGA development kit, allowed us to develop and deploy a complex custom design in very short time period. With the M9703A digitizer, U5340A and IPrium DDC, we managed to create a 64-channel system that met our customer's requirements without any compromise," (Figure4).

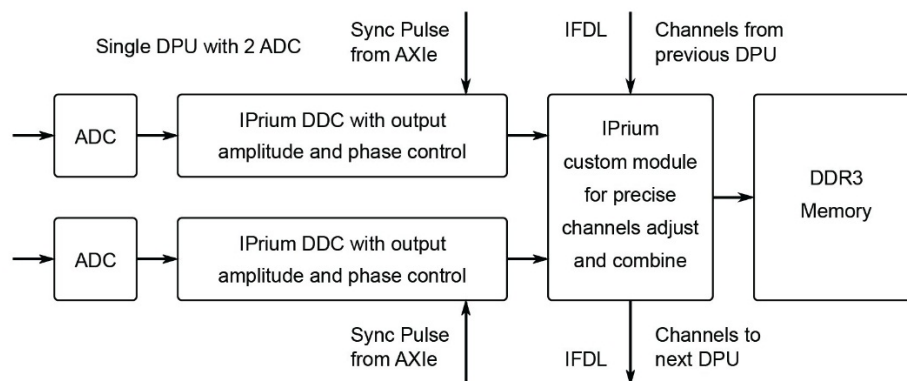

Figure 4. This block diagram shows the IPrium FPGA custom design implementation.

This multichannel data acquisition system with customized, real-time signal processing and unique phase coherency represents an important step towards data reduction and storage to be carried out at the digitizer level. Furthermore, the U5340A FPGA development kit is a complete environment for the design, verification and implementation of IP processing algorithms, allowing the development of a complex custom design. This combined hardware, software and people know-how represents a fast and integrated solution to our customer's requirements in one modular and scalable system.

To request more information or ask a product expert for the best and most cost-effective solution, please contact us at [digitizers@keysight.com](mailto:digitizers@keysight.com)

More information about Keysight product configuration is available at [www.keysight.com/find/M9703A](http://www.keysight.com/find/M9703A).

More information about IPrium IP processing algorithms implementation is available at [www.iprium.com](http://www.iprium.com).